

SYNTHESIS[®] LINE

battente



Synthesis[®] Line battente is ECLISSE solution that allows installing a hinged door flushing with the wall, this means a door with no frame: no jambs, no architraves.

According to your taste, the doors can be painted in the same colour of the wall, perfectly hiding from view, and blending in with the rest of the wall as much as possible in the pursuit of total continuity and formal rigor.

Alternatively, the door panel can be lacquered or decorated with finishing or prints that play them up, becoming real design elements.

SYNTESIS® LINE

battente



The same aesthetic and structural characteristics are present in the frameless sliding pocket door systems Syntesis® Line and Syntesis® Luce. Matching both solutions together, sliding and hinged, you can get a perfectly **coherent and minimal result.**

SYNTESIS® LINE

battente

CHOOSE THE OPENING DIRECTION

PUSH DOOR

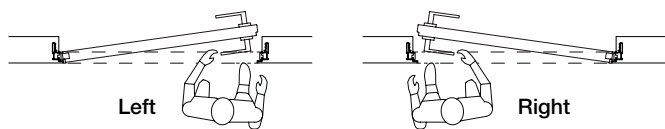

PULL DOOR

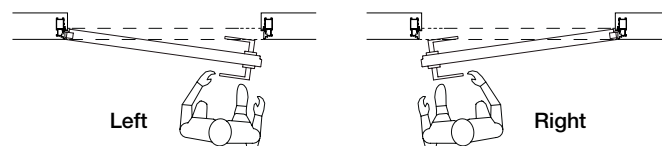

VERSION: WITH OR WITHOUT HEADER

The distinctive feature of Syntesis® Line battente is the possibility to install doors flush with the ceiling with or without header in order to achieve a total integration among door, wall and ceiling.

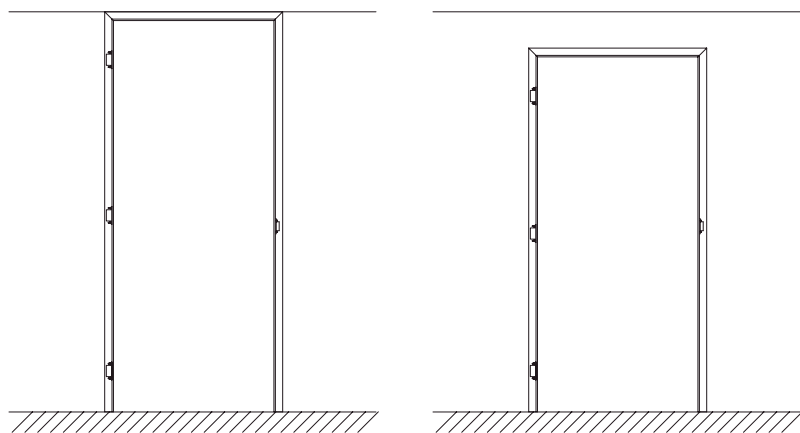

With header

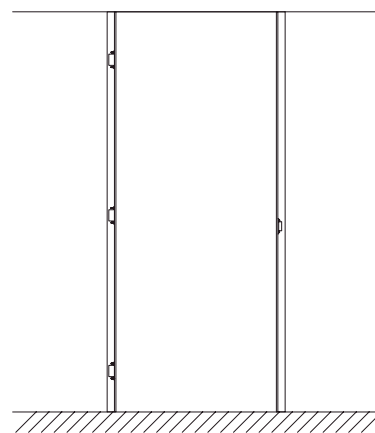

Without header

SUPPLY METHODS

COMPLETE SET



SINGLE ELEMENTS



The complete SET supply includes frame structure, door and hardware.

SYNTESIS® LINE

battente - THE ALUMINIUM FRAME



THE ADVANTAGES

- UNIQUE frame, for both stud and solid wall.
- Supplied in kit or pre-assembled with spacer panel in OSB 3, 25 mm thick in order to guarantee a perfect squaring of the frame (see point 7).
- Supplied with a plastic protection to avoid dirt and scratches in construction site.
- Bar code on the frame to identify the product.
- Door seal applicable on the frame, not on the door. Stable, easy to install, soft and aesthetically pleasant.
- Cover for door hinge to protect hinges from plaster (pull door version).

Trademark

The frame is recognisable thanks to the trademark.



Very strong frame

The frame profile weighs about 2 kg/m.

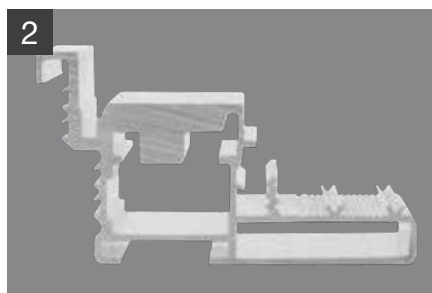

Long lasting

The aluminium frame is firstly subjected to a phosphate treatment against oxidation and then it is primer-coated to facilitate paint cohesion.



6 Adjustable clamps

The clamps are adjustable for height and prepared to be easily fixed to solid wall.



Quote 100

To help the installer finding the "0" quote.

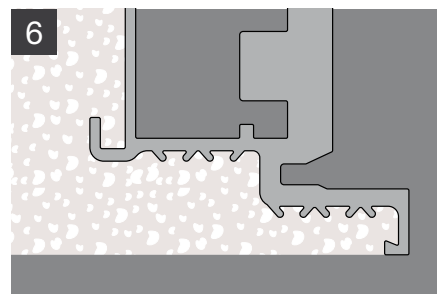

NO cracks!

The frame profile is specially designed to avoid cracks.

SYNTHESIS® LINE

battente - THE DOOR



THE ADVANTAGES

- The door is recognisable thanks to the trademark.
- Primer-coated to favour cohesion of wall paint and lacquer (both opaque and glossy).
- Universal outline adaptable to opening side (right or left).
- Thickness: 45 mm.
- Full hollow core with double solid wood perimeter to improve inflexibility.
- Border all along the perimeter.
- Door panel with height starting from H 2300 mm, are provided with a tensioning rod that improve the door flatness.
- The door panel is supplied only with a hole for handle; it's possible to install key lock or turn knob lock creating a second hole during installation.

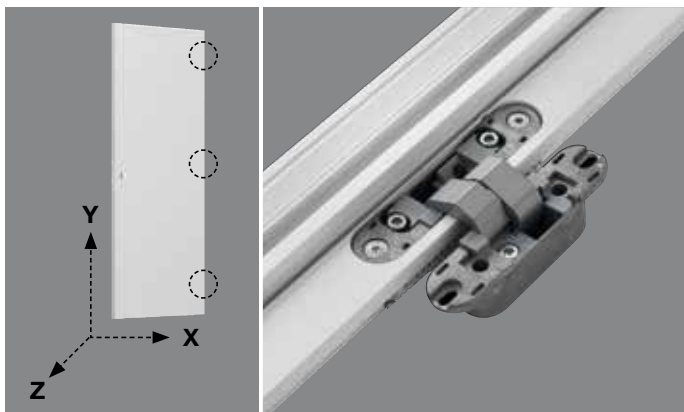

HINGES

3 Triple adjustable hinges (height, width, depth) for a perfect calibration of the perimeter size.

Note: when the door weighs more than 50 kg (max 65 kg), 4 hinges are needed.



MAGNETIC LOCK

Magnetic lock

It has modern design and minimal lines; it remains "flush" and guarantees an extraordinary softness while closing.

Eccentric strike plate

- Minimal design, it remains "flush".
- Eccentric: it allows fixing little installation imperfections, guaranteeing a perfect locking.

Note: it comes standard without lock or lock with key. Turn knob lock on request.

SYNTHESIS® LINE

battente - APPLICATIONS

The frame fits both with stud and solid wall.

Solid wall version: 6 clamps are cemented in the special spaces created in the wall.

Stud wall version: the frame is fixed with screws to the metal structure through the existing holes.

PUSH DOOR

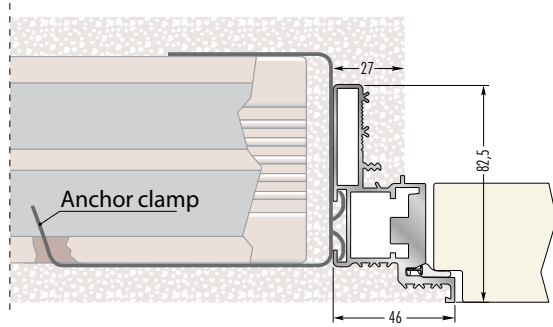

Frame on solid wall

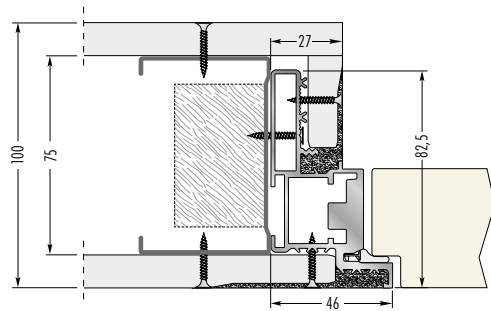

Frame on stud wall with one plate
Finished wall thickness 100 mm

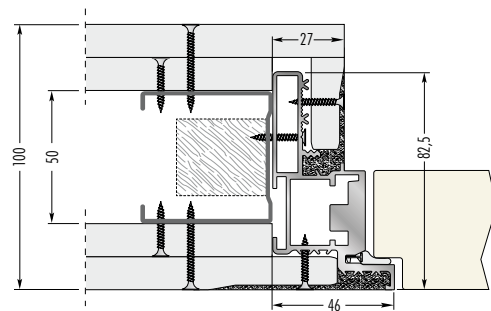

Frame on stud wall with two plates
Finished wall thickness 100 mm

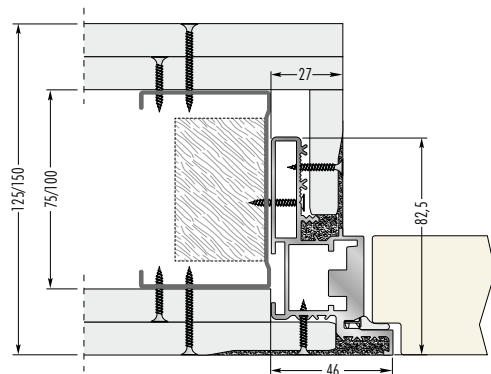

Frame on stud wall with three plates
Finished wall thickness 125/150 mm

PULL DOOR

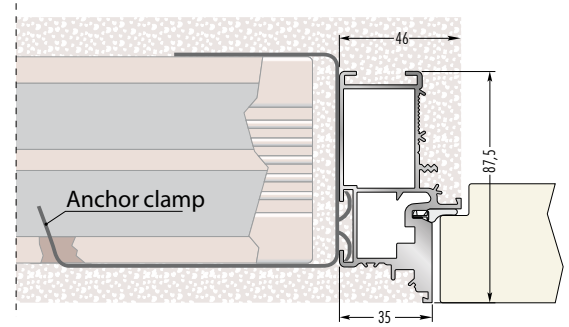

Frame on solid wall

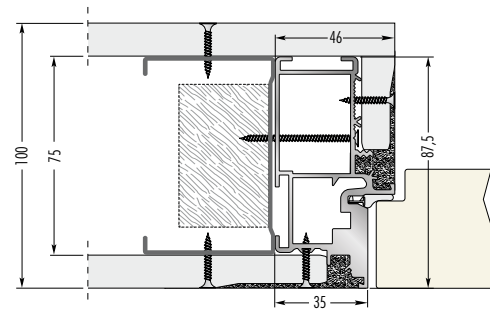

Frame on stud wall with one plate
Finished wall thickness 100 mm

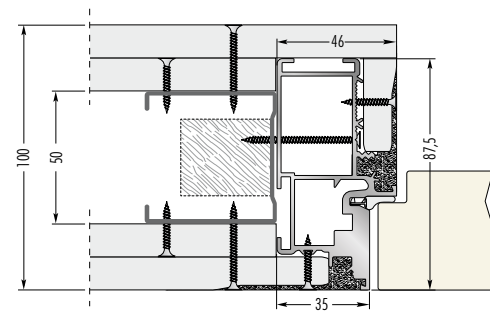

Frame on stud wall with two plates
Finished wall thickness 100 mm

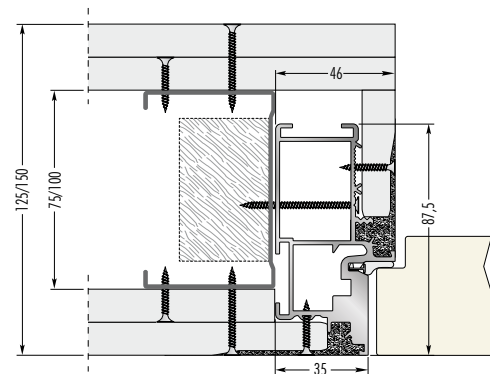

Frame on stud wall with three plates
Finished wall thickness 125/150 mm

SYNTESIS® LINE

battente - DIMENSIONS

PUSH DOOR

FRAME WITH HEADER

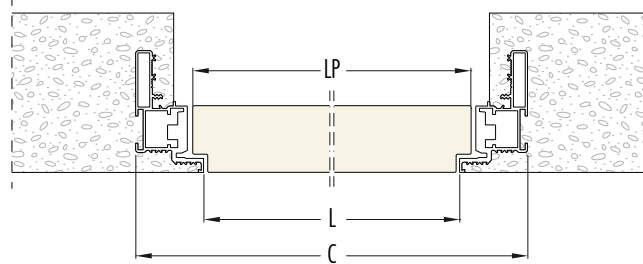
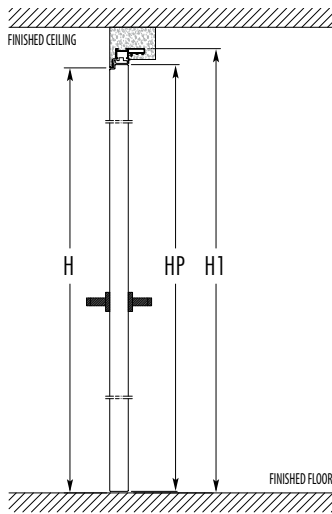

FRAME WITHOUT HEADER

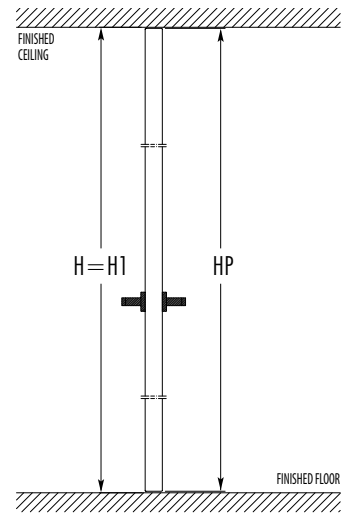

PULL DOOR

FRAME WITH HEADER

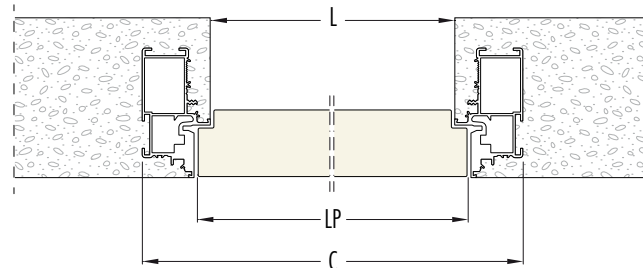
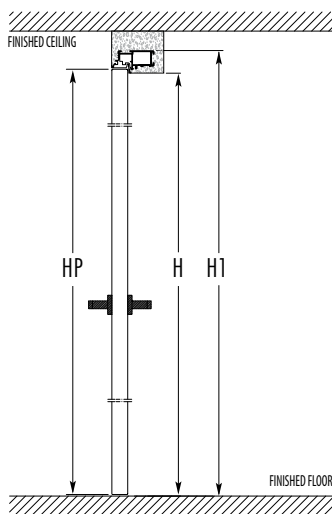

FRAME WITHOUT HEADER

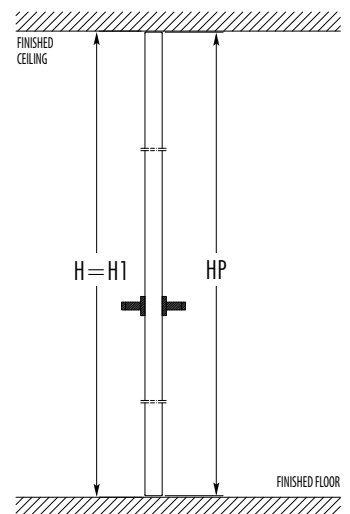

FRAME WITH RAIL

FRAME WITHOUT RAIL

PASSAGE SIZE		OVERALL DIMENSIONS		DOOR PANEL - 45 mm thick		PASSAGE SIZE		OVERALL DIMENSIONS		DOOR PANEL - 45 mm thick	
L	H	C	H1	LP	HP	L	H	C	H1	LP	HP
600	2100/2400	692	2146/2446	616	2104/2404	600	2700	692	2700	616	2693
650	2100/2400	742	2146/2446	666	2104/2404	650	2700	742	2700	666	2693
700	2100/2400	792	2146/2446	716	2104/2404	700	2700	792	2700	716	2693
750	2100/2400	842	2146/2446	766	2104/2404	750	2700	842	2700	766	2693
800	2100/2400	892	2146/2446	816	2104/2404	800	2700	892	2700	816	2693
850	2100/2400	942	2146/2446	866	2104/2404	850	2700	942	2700	866	2693
900	2100/2400	992	2146/2446	916	2104/2404	900	2700	992	2700	916	2693
950	2100/2400	1042	2146/2446	966	2104/2404	950	2700	1042	2700	966	2693
1000	2100/2400	1092	2146/2446	1016	2104/2404	1000	2700	1092	2700	1016	2693

Dimensions are given in mm

- ▶ INTERVAL FOR HEIGHT EVERY 50 mm, from 1800 mm to 2700 mm.
- ▶ FRAME WITH HEADER: HEIGHT OVERALL DIMENSION IS ALWAYS MORE THAN 46 mm COMPARED TO HEIGHT SIZE H.
- ▶ FRAME WITH HEADER: IT'S POSSIBLE TO HAVE A VARIATION WITH HEIGHT OVERALL DIMENSION 2700 mm AND PASSAGE SIZE 2654 mm.